

## Appendix 6 – Light Sheet Configurations

### A6-1 Introduction

These pages give a graphical and thus relatively intuitive overview of the different possible light sheet configurations and the resulting light sheet parameters (back focal length  $bfl$  = working distance, focal length  $f$  and light sheet width at the beam waist).

### A6-2 Configuration 1 ~ 450 mm – 810 mm

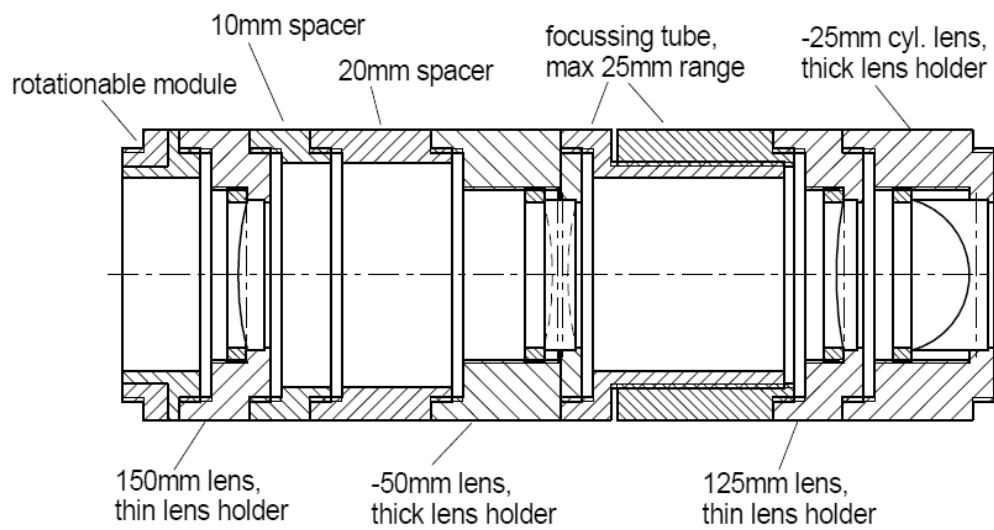

Figure A6-1 Light sheet configuration 1 - sketch.

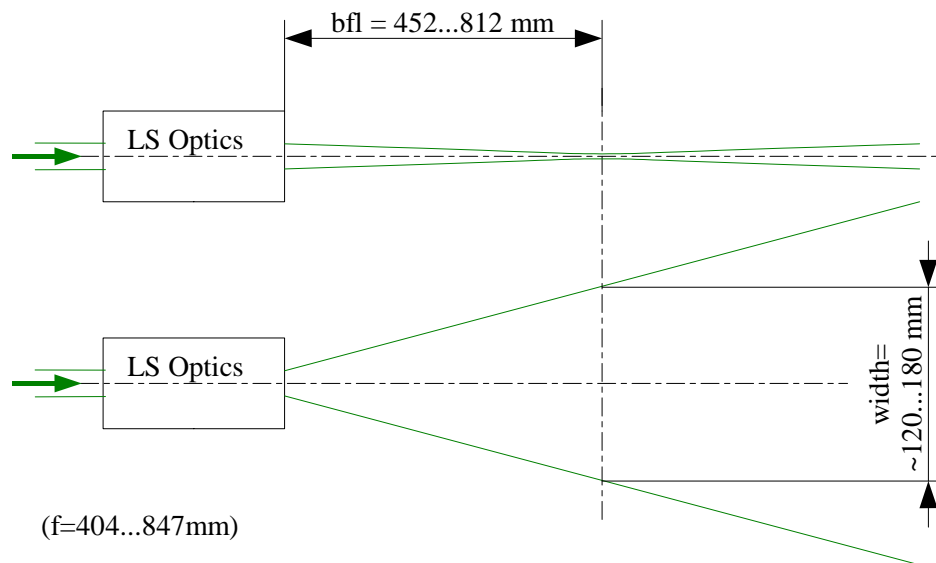

Figure A6-2 Light sheet configuration 1 - specifications.

Appendix 6 – Light Sheet Configurations

Light sheet configuration 1 is the standard configuration to be used for objects at a short distance from the laser.

**A6-3 Configuration 2 ~ 530 mm – 1240 mm**

The difference between configuration 2 and 1 is that now the 10mm spacing ring is removed, resulting in a larger working distance.

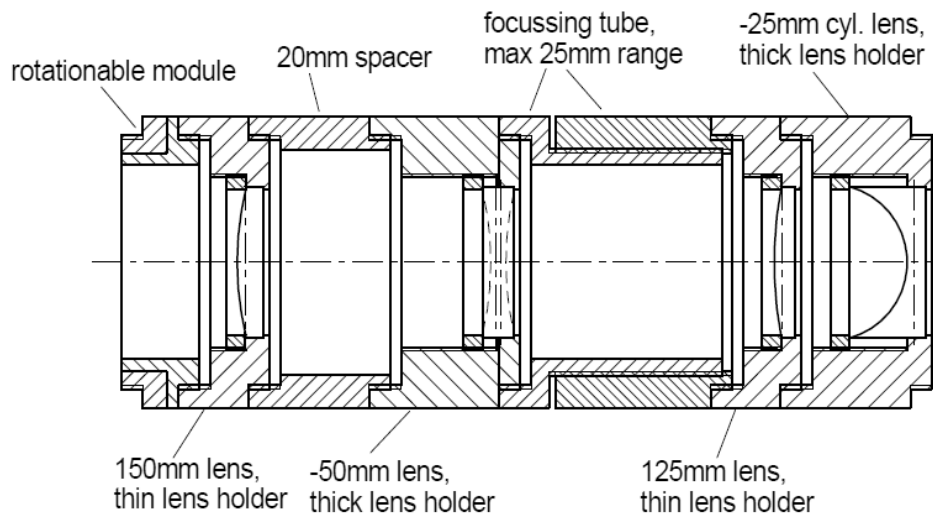

Figure A6-3 Light sheet configuration 2 - sketch.

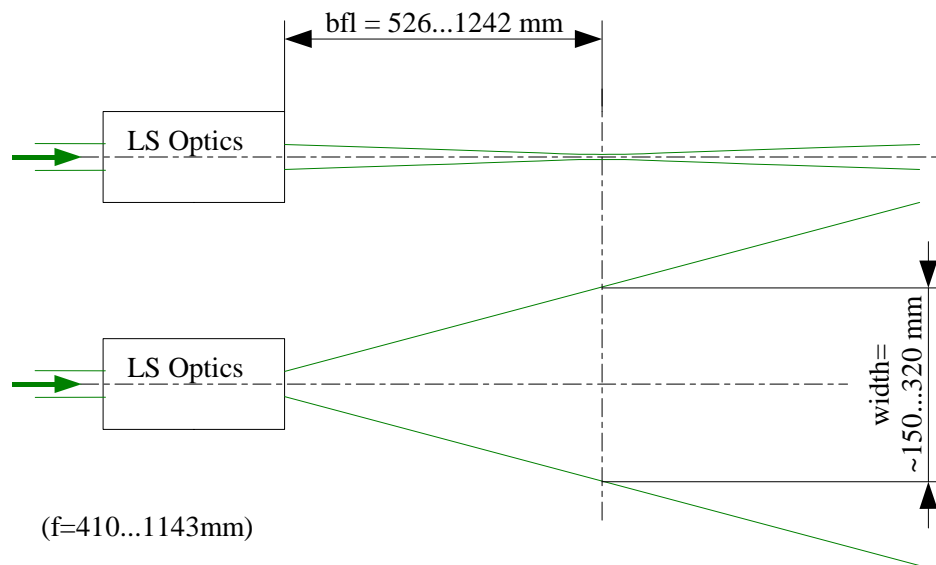

Figure A6-4 Light sheet configuration 2 - specifications.

### A6-4 Configuration 3 ~ 1100 mm – ~3000 mm

The difference between configuration 3 and 1 is the last focussing lens which is changed from 125mm to 150mm. This results in a focal length range up to infinity beginning at a bit more than one metre.

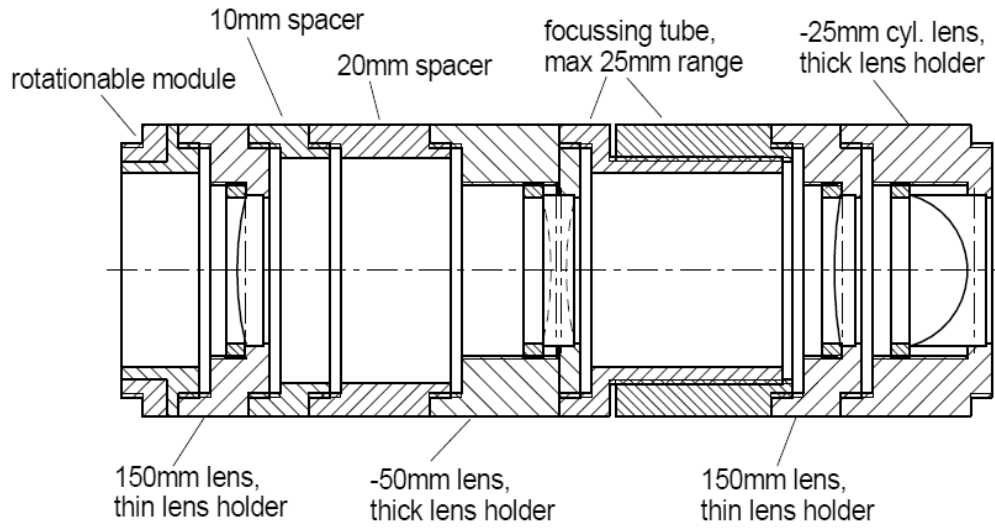

Figure A6-5 Light sheet configuration 3 - sketch.

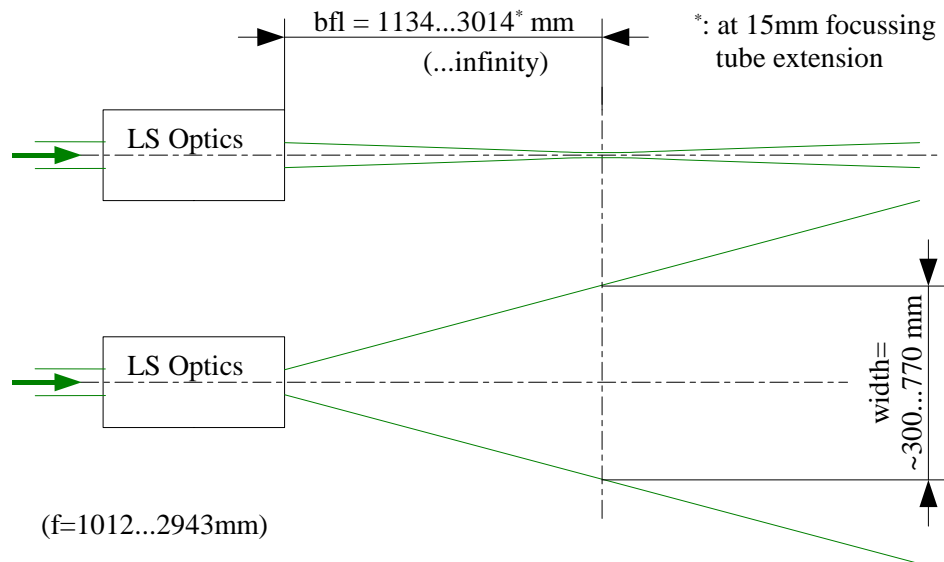

Figure A6-6 Light sheet configuration 3 - specifications.

### A6-5 Smaller Light Sheet Angle

It is possible to decrease the light sheet angle by exchanging the -25mm cylindrical lens with the -50mm cylindrical lens shown in Figure A6-7. The resulting light sheet width at the waist will be roughly halved.

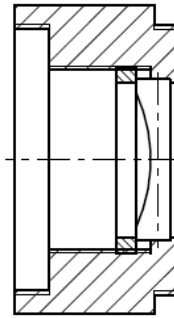

Figure A6-7  $f=-50\text{mm}$  cylindrical lens for a smaller light sheet angle.

### A6-6 Larger Light Sheet Angle

To make a larger light sheet angle it is necessary to use a cylindrical lens with a focal length larger (i.e. smaller magnitude) than -25mm or to place two cylindrical lenses in series. Switching the lenses in series requires them to be aligned to each other. Using a lens smaller than -25mm will require to manufacture a special fixture as such lenses will no longer fit into the standard Edmund Optics fixtures used. Note that reducing the focal length will reduce the lens cross section, which requires more stringent laser beam alignment to the optical axis of the light sheet as small alignment errors are now much likelier to hit the edge of the smaller lens.